

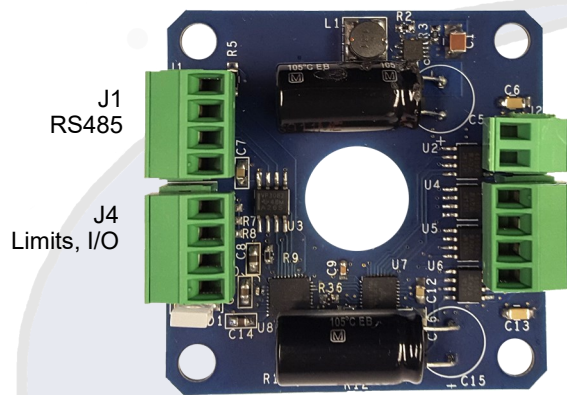

## Connector Pin-out



**J2**  
Pin 1: +12 to +50VDC  
Pin 2: Ground

**J3**  
Pin 1: Phase 1A  
Pin 2: Phase 1B  
Pin 3: Phase 2A  
Pin 4: Phase 2B

## Typical Application



## Dimensions

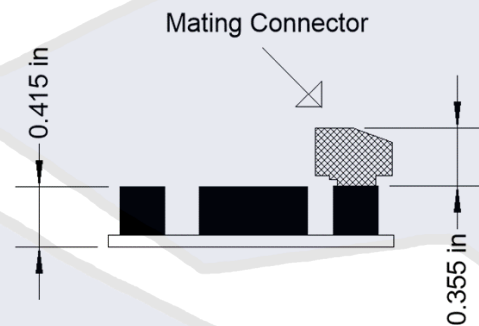
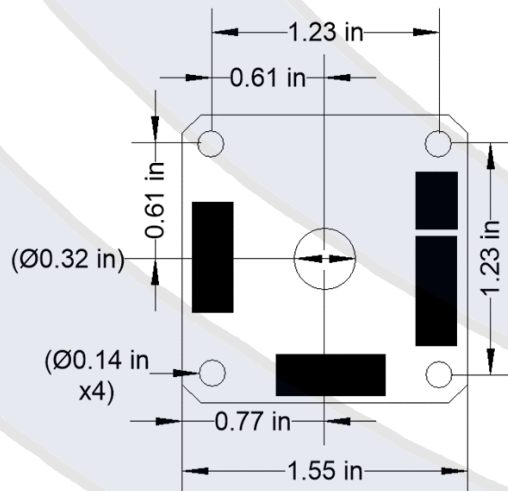

## ORDERING INFORMATION

Model	Description
OMD24	Controller & MicroStep Driver, Size 23

**OMS Motion, Inc.**

15201 NW Greenbrier Pkwy, B-1  
Beaverton, OR 97006

1(800) 707-8111, 503-629-8081  
Fax: 503-629-0688

[www.OMSmotion.com](http://www.OMSmotion.com)

